

SEPARATORS

INSTALLATION SIZE VE15

▶ PRODUCT SPECIFICATIONS



▶ Forces and moments

Shows static forces and torques that may be present on the plunger

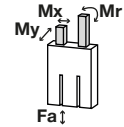

Mr [Nm]	5
Mx [Nm]	5
My [Nm]	5
Fa [N]	100

▶ RECOMMENDED ACCESSORIES



ENERGY SUPPLY



GVM5
Straight Fittings - Quick Connect Style



WVM5
Angled Fittings - Quick Connect Style



SENSORS



KB8-20
Mounting block



NJ8-E2
Inductive proximity switch - Cable 5 m



NJ8-E2S
Inductive proximity switch - Connector M8



MFS01-K-KHC-P1-PNP
Magnetic field sensor angled, cable 5 m



SENSORS



MFS01-S-KHC-P1-PNP
Magnetic field sensor angled, cable 0.3 m - M8 connector



MFS02-K-KHC-P1-PNP
Magnetic field sensor straight, cable 5 m



MFS02-S-KHC-P1-PNP
Magnetic field sensor straight, cable 0.3 m - M8 connector



CONNECTIONS / OTHER



KAG500
Plug-in connector Straight Cable 5m - Socket M8 (female)



KAW500
Plug-in connector Angled Cable 5m - Socket M8 (female)

Order no.	VE15-B
Stroke per tapped rod [mm]	40
Force in extend [N]	80
Force in retract [N]	65
Self locking mechanism	mechanical
Cycle count [s]	0.1
Repetition accuracy +/- [mm]	0.1
Operating pressure min. [bar]	3
Operating pressure max. [bar]	8
Nominal operating pressure [bar]	6
Operating temperature min. [°C]	5
Operating temperature max. [°C]	+80
Air volume per cycle [cm ³]	23
Weight [kg]	0.48

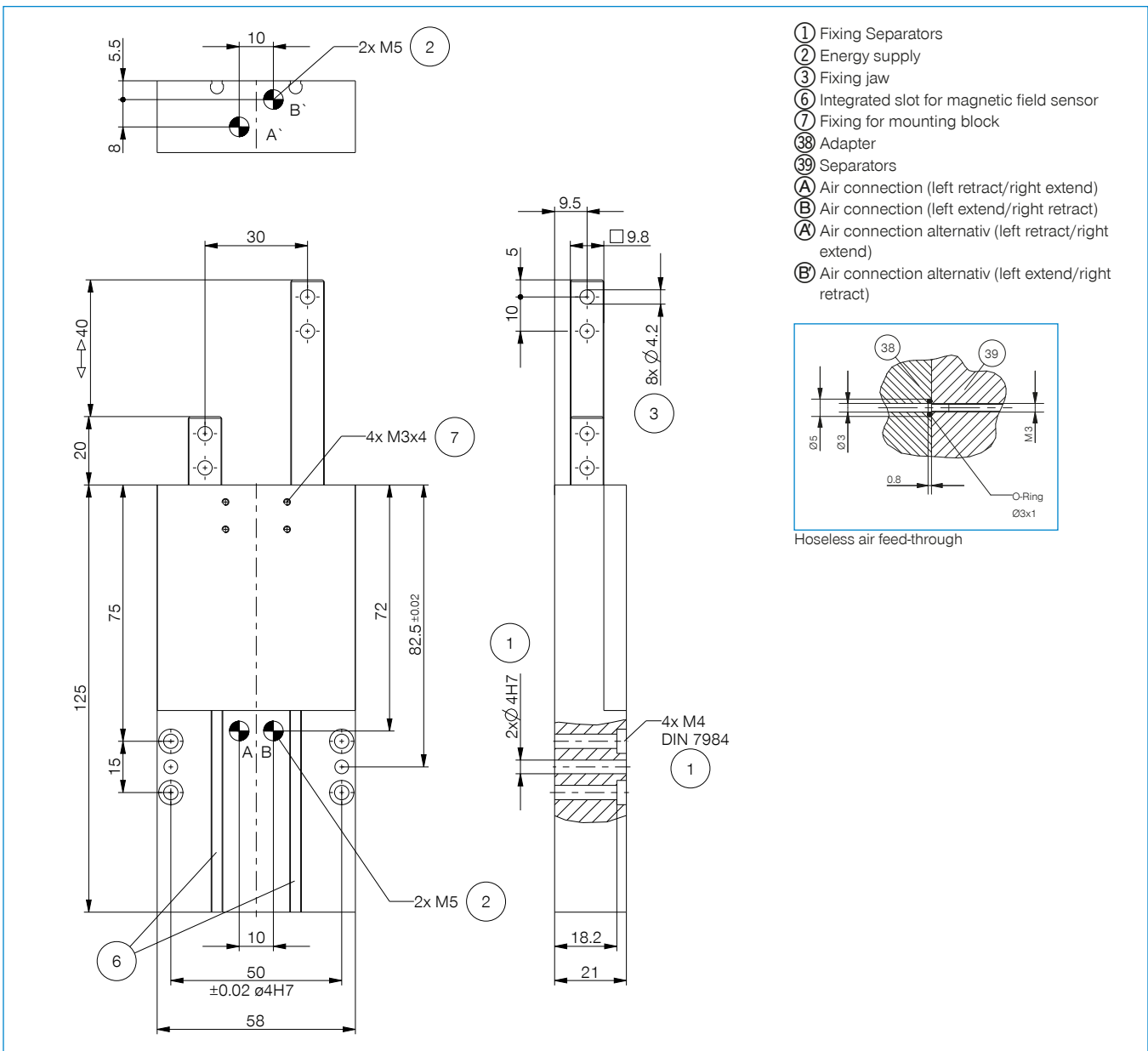

SEPARATORS

SERIES VE

▶ PRODUCT ADVANTAGES

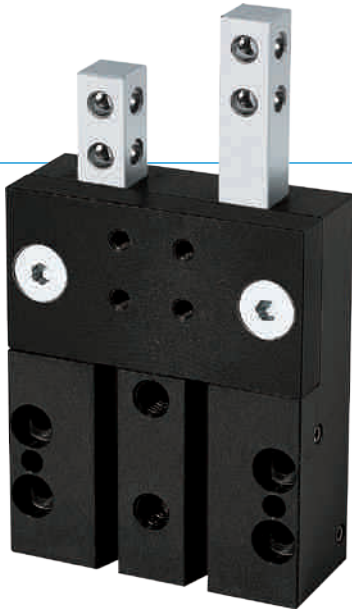

▶ Mechanical forced control

Guarantees process reliability for your application since only one workpiece can be separated and guided through at a time

▶ Decide for yourself!

Sensing via magnetic field sensors or inductive proximity switches: Unlike the benchmark, you are free to choose!

▶ Failure-free continuous operation

Our uncompromising “Made in Germany” quality guarantees up to 10 million maintenance-free cycles

▶ SERIES CHARACTERISTICS

Installation size

VEXX

 10 million maintenance-free cycles (max.)	●
 Inductive sensor	●
 Magnetic field sensor	●
 IP40	●



► BENEFITS IN DETAIL

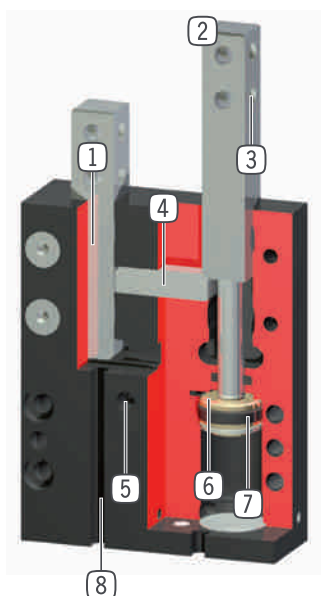

- ① **Square guide**
 - rugged, high forces and moments capacity
- ② **Tapped rod**
 - hardened steel
- ③ **Mounting**
 - individual separator finger mounting
- ④ **Locking**
 - integrated, mechanical locking
- ⑤ **Energy supply**
 - possible from several sides
- ⑥ **Drive**
 - two double-acting pneumatic cylinders
- ⑦ **Permanent magnet**
 - installed in piston area
- ⑧ **Sensing**
 - groove for positioning of the magnetic field sensor

► TECHNICAL DATA

Installation size	Stroke [mm]	Force in retract [N]	Force in extend [N]	Weight [kg]	IP class
VE10	10	30	40	0.12	IP40
VE14	20	65	80	0.3	IP40
VE15	40	65	80	0.48	IP40
VE22	30	170	220	0.915	IP40
VE23	60	170	220	1.5	IP40

► FURTHER INFORMATION IS AVAILABLE ONLINE



All information just a click away at: www.zimmer-group.com. Find data, illustrations, 3D models and operating instructions for your installation size using the order number for your desired product. Quick, clear and always up-to-date.