

LINEAR RAIL SLIDES

LSX40-200

▶ PRODUCT SPECIFICATIONS



▶ Time diagram

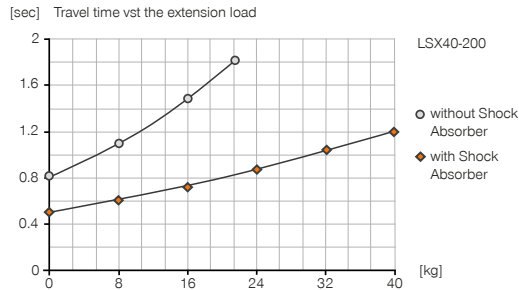

▶ Forces and moments

Max allowable static forces and moments on face A.

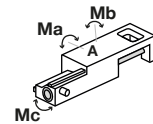

Ma [Nm]	200
Mb [Nm]	200
Mc [Nm]	200

▶ Load diagram

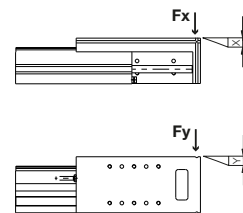
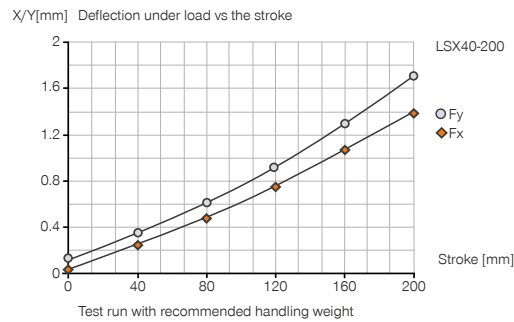

▶ RECOMMENDED ACCESSORIES



ENERGY SUPPLY



DRV1-8X6
Flow Control Valves - with Swivel joint



CONNECTIONS / OTHER



APLSX40V
Adapter plate



SENSORS



MFS02-K-KHC-P1-PNP
Magnetic field sensor straight, cable 5 m



M20X1.5S
Shock Absorbers



KAG500
Plug-in connector Straight Cable 5m - Socket M8 (female)



MFS02-S-KHC-P1-PNP
Magnetic field sensor straight, cable 0.3 m - M8 connector



KAW500
Plug-in connector Angled Cable 5m - Socket M8 (female)



CONNECTIONS / OTHER



APLSX40G
Adapter plate



S8-G-3
Plug-in connector customizable Straight - Connector M8



S12-G-3
Plug-in connector customizable Straight - Connector M12

Order no.	Technical data
Stroke [mm]	200
Pressure force max. [N]	750
Retraction force [N]	680
Recommended handling weight [kg]	40
Piston diameter [mm]	40
Guide rail size [mm]	30
Nominal operating pressure [bar]	6
Operating temperature min. [°C]	5
Operating temperature max. [°C]	+80
Air volume per cycle [cm³]	235
Weight [kg]	4.4

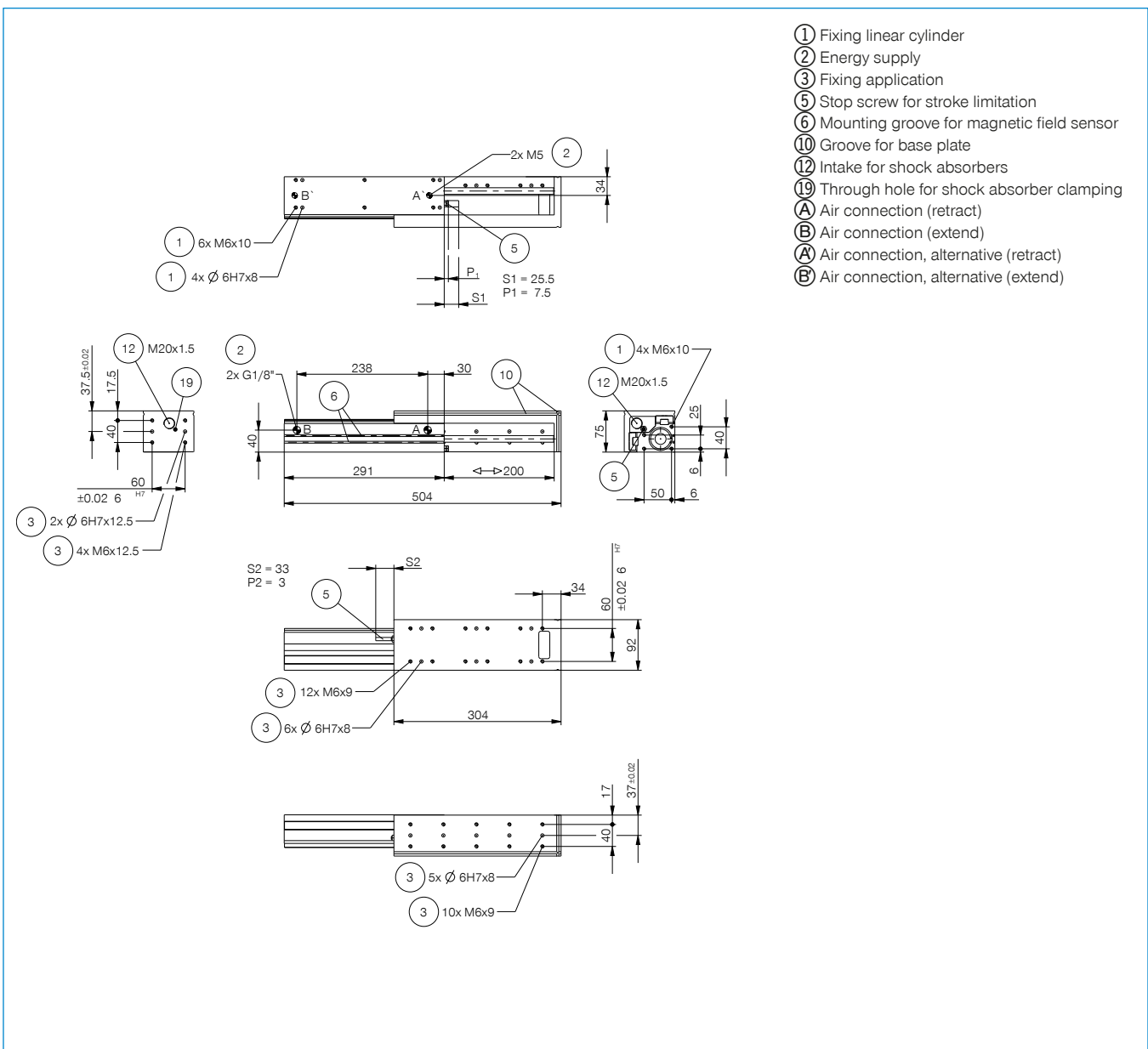

LINEAR RAIL SLIDES

SERIES LSX

▶ PRODUCT ADVANTAGES

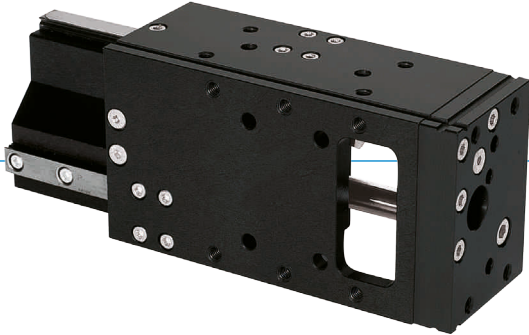

▶ **Precise double rail profile guide**

The linear guide with ball bearing circulation and scrapers provides high precision and rigidity

▶ **Dampened end position**

By using PowerStop shock absorbers, you can gently move up to the end positions, increasing the process reliability and durability of your application

▶ **Failure-free continuous operation**

Our uncompromising “Made in Germany” quality guarantees up to 10 million maintenance-free cycles

▶ SERIES CHARACTERISTICS

Installation size

LSXYY-YY

	LSXYY-YY
 10 million maintenance-free cycles (max.)	●
 Magnetic field sensor	●
 Powerstop end position damping	●
 IP40	●



► BENEFITS IN DETAIL

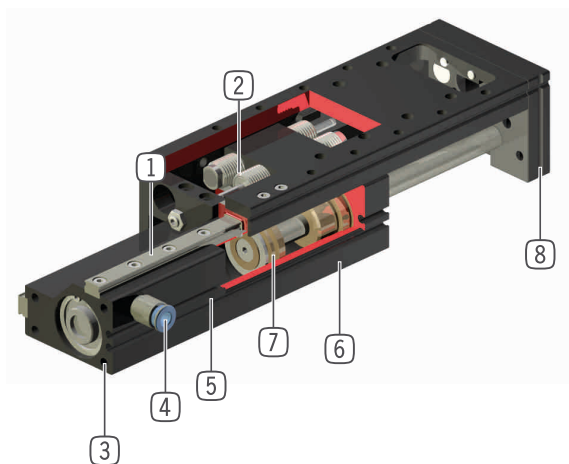

- ① **Linear guide with recirculating ball and wiper**
 - two way linear guide for forces and moments capacity
- ② **Patented, hydraulic shock absorber**
 - adjustable end position damping
 - included in scope of delivery
- ③ **Mounting and positioning**
 - mounting possible from several sides for versatile positioning
- ④ **Energy supply**
 - possible from several sides
- ⑤ **Mounting groove for magnetic field sensor**
 - integrated, space saving position sensing
- ⑥ **Robust, lightweight housing**
 - Hard-coated aluminum alloy
- ⑦ **Drive**
 - double-acting pneumatic cylinder
- ⑧ **Intake flange**
 - quick and cost-effective positioning of adapter plates: Accessory, Art. No. AP...G and AP...V

► TECHNICAL DATA

Installation size	Stroke [mm]	Pressure force max. [N]	Retraction force [N]	Weight [kg]	IP class
LSX25	50 - 200	265	220	1 - 1,9	IP40
LSX40	100 - 200	750	680	3,2 - 4,4	IP40

► FURTHER INFORMATION IS AVAILABLE ONLINE



All information just a click away at: www.zimmer-group.com. Find data, illustrations, 3D models and operating instructions for your installation size using the order number for your desired product. Quick, clear and always up-to-date.