

# LINEAR RAIL SLIDES

## LSX25-200

### ▶ PRODUCT SPECIFICATIONS



#### ▶ Time diagram

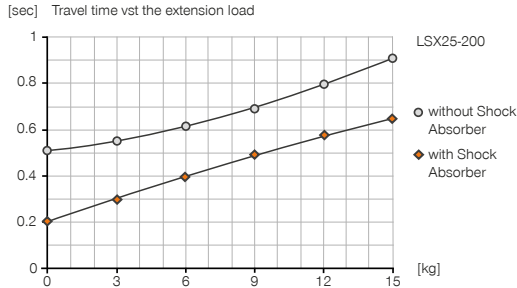

#### ▶ Forces and moments

Max allowable static forces and moments on face A.

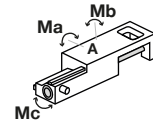

Ma [Nm]	55
Mb [Nm]	55
Mc [Nm]	55

#### ▶ Load diagram

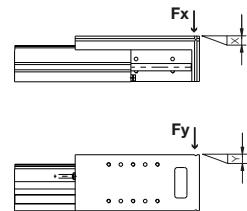
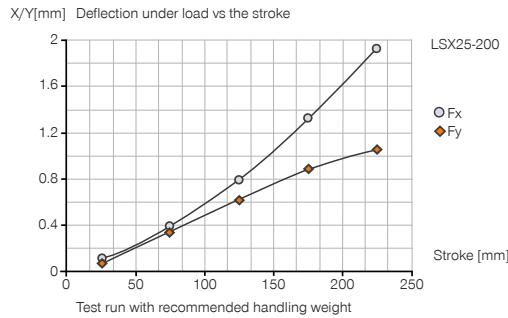

### ▶ RECOMMENDED ACCESSORIES



#### ENERGY SUPPLY



**DRV1-8X6**  
Flow Control Valves - with Swivel joint



#### CONNECTIONS / OTHER



**APLSX25V**  
Adapter plate



#### SENSORS



**MFS02-K-KHC-P1-PNP**  
Magnetic field sensor straight, cable 5 m



**M12X1S**  
Shock Absorbers



**KAG500**  
Plug-in connector Straight Cable 5m - Socket M8 (female)



**MFS02-S-KHC-P1-PNP**  
Magnetic field sensor straight, cable 0.3 m - M8 connector



**KAW500**  
Plug-in connector Angled Cable 5m - Socket M8 (female)



#### CONNECTIONS / OTHER



**APLSX25G**  
Adapter plate



**S8-G-3**  
Plug-in connector customizable Straight - Connector M8



**S12-G-3**  
Plug-in connector customizable Straight - Connector M12

▶ Technical data	
<b>Order no.</b>	<b>LSX25-200</b>
Stroke [mm]	200
Pressure force max. [N]	265
Retraction force [N]	220
Recommended handling weight [kg]	15
Piston diameter [mm]	25
Guide rail size [mm]	18
Nominal operating pressure [bar]	6
Operating temperature min. [°C]	5
Operating temperature max. [°C]	+80
Air volume per cycle [cm³]	180
Weight [kg]	1.9

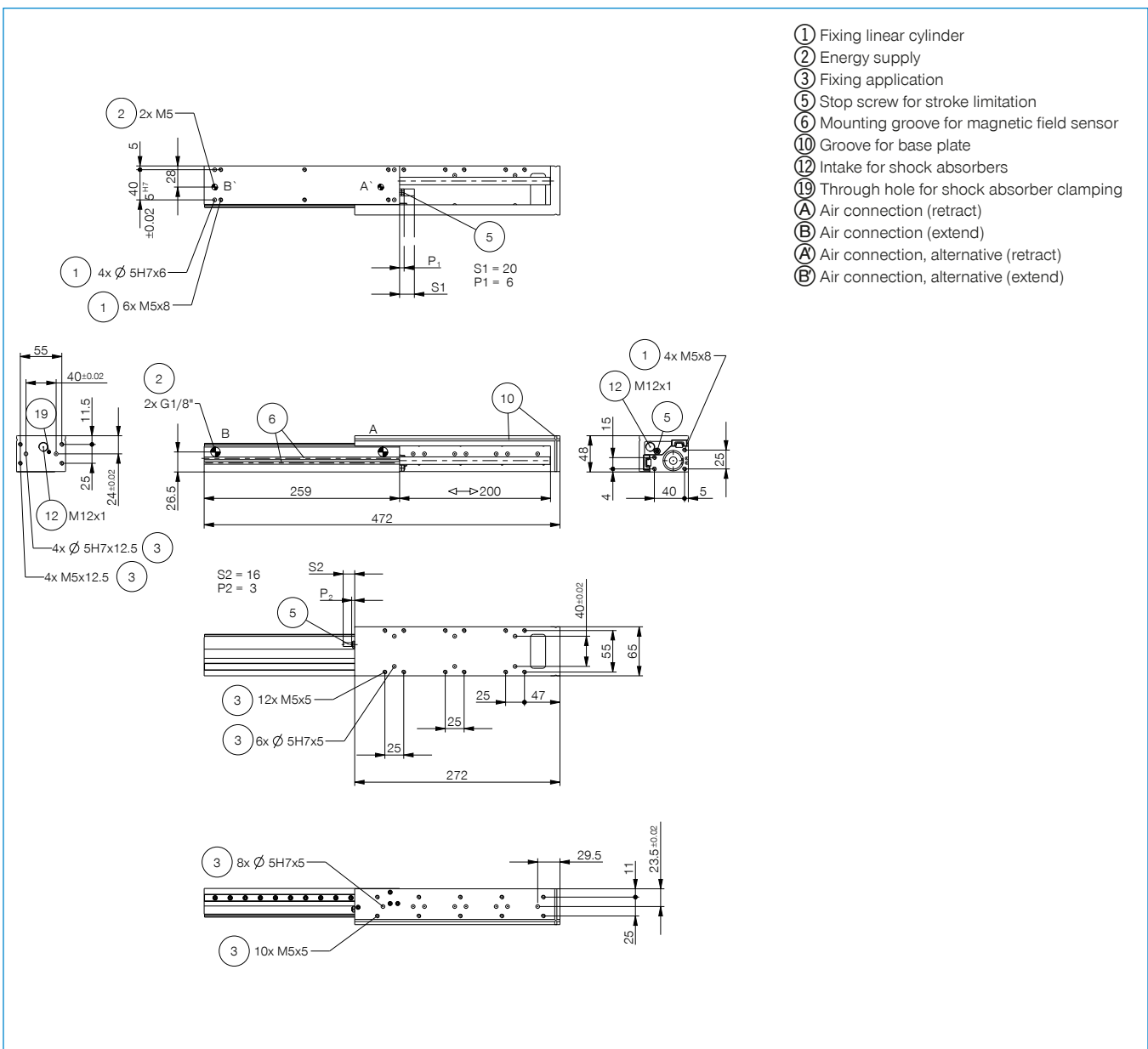

# LINEAR RAIL SLIDES

## SERIES LSX

### ▶ PRODUCT ADVANTAGES

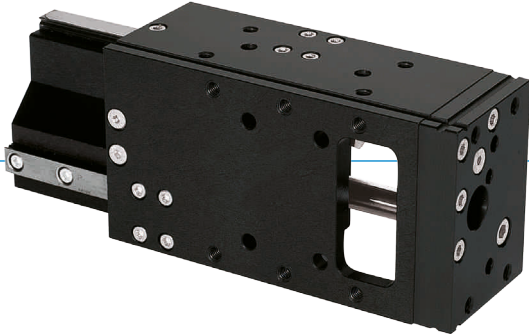

#### ▶ **Precise double rail profile guide**

The linear guide with ball bearing circulation and scrapers provides high precision and rigidity

#### ▶ **Dampened end position**

By using PowerStop shock absorbers, you can gently move up to the end positions, increasing the process reliability and durability of your application

#### ▶ **Failure-free continuous operation**

Our uncompromising “Made in Germany” quality guarantees up to 10 million maintenance-free cycles

### ▶ SERIES CHARACTERISTICS

#### Installation size

LSXYY-YY

 <b>10 million maintenance-free cycles (max.)</b>	●
 <b>Magnetic field sensor</b>	●
 <b>Powerstop end position damping</b>	●
 <b>IP40</b>	●



## ► BENEFITS IN DETAIL

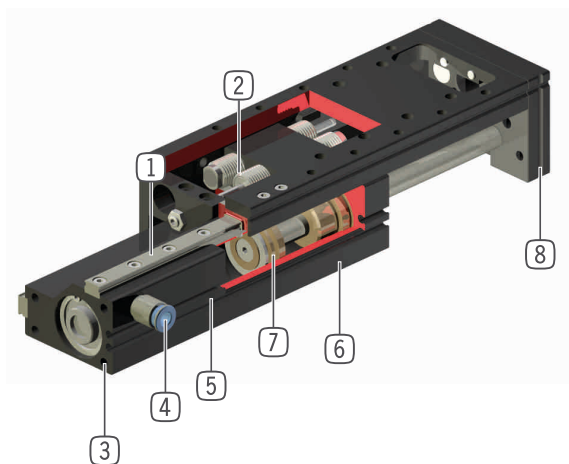

- ① **Linear guide with recirculating ball and wiper**
  - two way linear guide for forces and moments capacity
- ② **Patented, hydraulic shock absorber**
  - adjustable end position damping
  - included in scope of delivery
- ③ **Mounting and positioning**
  - mounting possible from several sides for versatile positioning
- ④ **Energy supply**
  - possible from several sides
- ⑤ **Mounting groove for magnetic field sensor**
  - integrated, space saving position sensing
- ⑥ **Robust, lightweight housing**
  - Hard-coated aluminum alloy
- ⑦ **Drive**
  - double-acting pneumatic cylinder
- ⑧ **Intake flange**
  - quick and cost-effective positioning of adapter plates: Accessory, Art. No. AP...G and AP...V

## ► TECHNICAL DATA

Installation size	Stroke [mm]	Pressure force max. [N]	Retraction force [N]	Weight [kg]	IP class
LSX25	50 - 200	265	220	1 - 1,9	IP40
LSX40	100 - 200	750	680	3,2 - 4,4	IP40

## ► FURTHER INFORMATION IS AVAILABLE ONLINE



All information just a click away at: [www.zimmer-group.com](http://www.zimmer-group.com). Find data, illustrations, 3D models and operating instructions for your installation size using the order number for your desired product. Quick, clear and always up-to-date.