

LINEAR RAIL SLIDES

LS10-25

▶ PRODUCT SPECIFICATIONS



▶ Time diagram

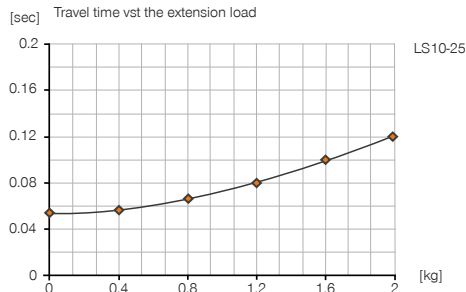

▶ Forces and moments

Max allowable static forces and moments on face A.

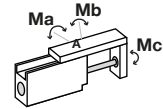

Ma [Nm]	3.2
Mb [Nm]	3.2
Mc [Nm]	5.1

▶ Load diagram

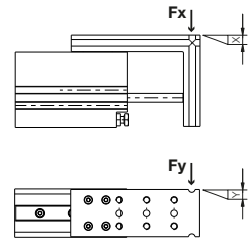
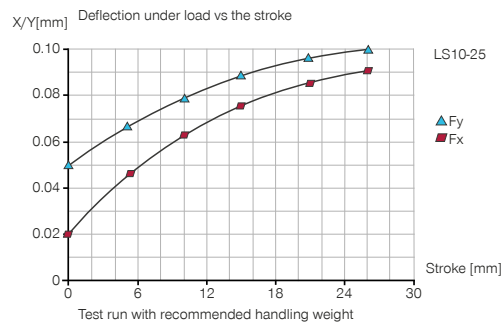

▶ RECOMMENDED ACCESSORIES



ENERGY SUPPLY



DRV3M4
Flow Control Valves - with Swivel joint



DSV1-8
Pressure safety valve



DSV1-8E
Pressure safety valve with quick exhaust



SENSORS



MFS02-K-KHC-P1-PNP
Magnetic field sensor straight, cable 5 m



MFS02-S-KHC-P1-PNP
Magnetic field sensor straight, cable 0.3 m - M8 connector



CONNECTIONS / OTHER



APLS10G
Adapter plate



KAG500
Plug-in connector Straight Cable 5m - Socket M8 (female)



KAW500
Plug-in connector Angled Cable 5m - Socket M8 (female)



S8-G-3
Plug-in connector customizable Straight - Connector M8



S12-G-3
Plug-in connector customizable Straight - Connector M12

► **Technical data**

Order no.	LS10-25
Stroke [mm]	25
Pressure force max. [N]	40
Retraction force [N]	30
Piston diameter [mm]	10
Guide rail size [mm]	7
Nominal operating pressure [bar]	6
Operating temperature min. [°C]	5
Operating temperature max. [°C]	+80
Air volume per cycle [cm ³]	3.6
Weight [kg]	0.15

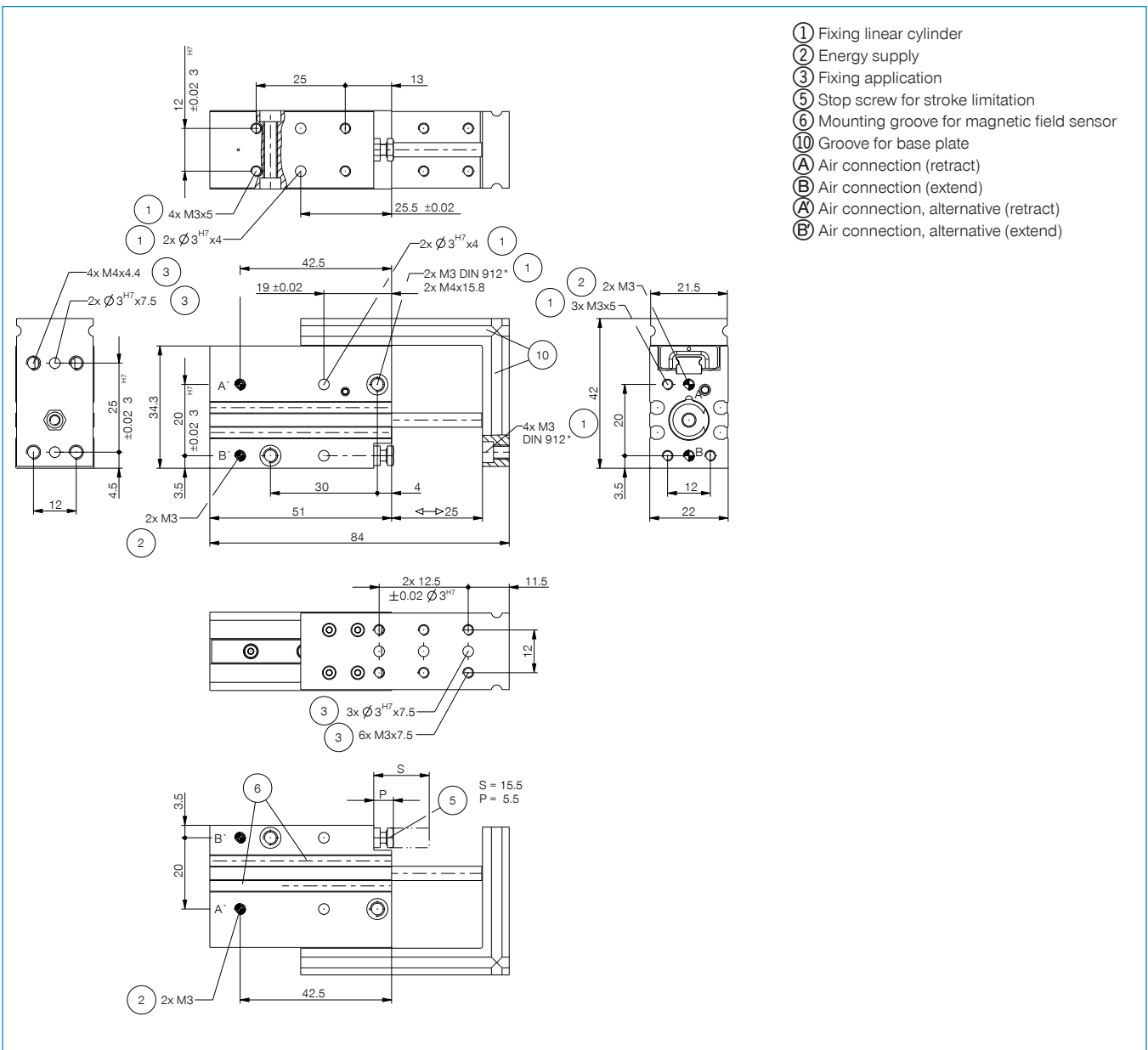

- ① Fixing linear cylinder
- ② Energy supply
- ③ Fixing application
- ⑤ Stop screw for stroke limitation
- ⑥ Mounting groove for magnetic field sensor
- ⑩ Groove for base plate
- A Air connection (retract)
- B Air connection (extend)
- A Air connection, alternative (retract)
- B Air connection, alternative (extend)



LINEAR RAIL SLIDES

SERIES LS

▶ PRODUCT ADVANTAGES

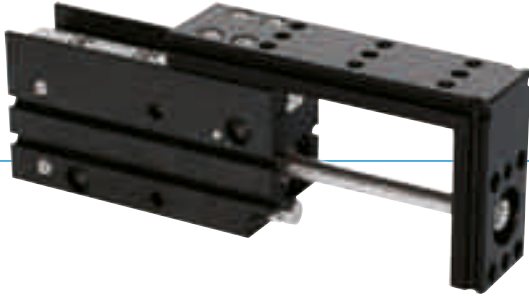

▶ **Precise profile guide**

The linear guide with ball bearing circulation and scrapers provides high precision and rigidity



▶ **Standardised adapter plate**

Reduce your manufacturing effort and ensure standardisation for your follow-on tools

▶ **Modular layout**

Makes it possible to combine several units directly to each other and to minimise your design effort

▶ SERIES CHARACTERISTICS

		Installation size
		LSXX-XX
 10 million maintenance-free cycles (max.)		●
 Magnetic field sensor		●
 IP40		●



► BENEFITS IN DETAIL

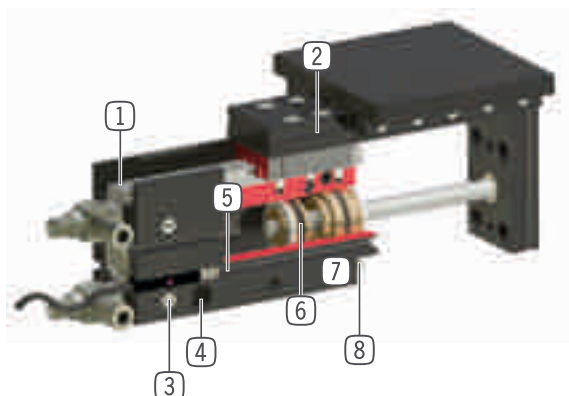

- ① **Linear guide with recirculating ball and wiper**
 - dual linear guidance for high forces and moments capacity
- ② **Mounting groove**
 - quick and cost-effective positioning of adapter plates: Accessory, Art. No. AP..G
- ③ **Energy supply**
 - possible from several sides
- ④ **Mounting and positioning**
 - mounting possible from several sides for versatile positioning
- ⑤ **Mounting groove for magnetic field sensor integrated, space saving position sensing**
- ⑥ **Drive**
 - double-acting pneumatic cylinder
- ⑦ **Robust, lightweight housing**
 - Hard-coated aluminum alloy
- ⑧ **Stroke limiting screw**

► TECHNICAL DATA

Installation size	Stroke [mm]	Pressure force max. [N]	Retraction force [N]	Weight [kg]	IP class
LS10	25 - 50	40	30	0,15 - 0,2	IP40
LS16	25 - 50	100	85	0,25 - 0,3	IP40

► FURTHER INFORMATION IS AVAILABLE ONLINE



All information just a click away at: www.zimmer-group.com. Find data, illustrations, 3D models and operating instructions for your installation size using the order number for your desired product. Quick, clear and always up-to-date.