

# MAGNETIC GRIPPER

## SERIES HM1000

### ▶ PRODUCT ADVANTAGES



#### ▶ **Secure hold during EMERGENCY STOP**

Magnets attached to springs ensure your workpiece remains secure, even during a drop in pressure



#### ▶ **Contact plate that increases friction value**

The replaceable O-ring ensures the high dynamics in your application and protection of your workpiece

#### ▶ **Residual holding force < 1N**

The demagnetised contact surface safeguards the process reliability of dropping off your workpiece

### ▶ SERIES CHARACTERISTICS

Installation size	Version
HM10XX	NC
 <b>5 million maintenance-free cycles (max.)</b>	●
 <b>IP30</b>	●



## ► BENEFITS IN DETAIL

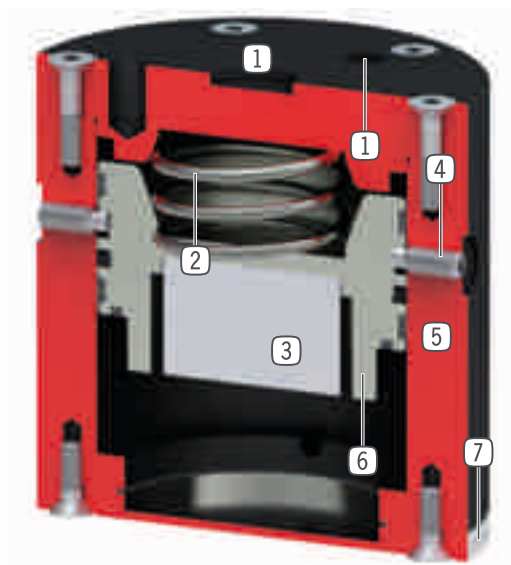

- ① **Mounting and positioning**
  - via centering sleeve and thread
- ② **Spring**
  - for piston return
  - secured holding even in drop pressure
- ③ **Permanent magnet**
  - requires no power supply
  - high holding forces
- ④ **Transport safeguarding**
- ⑤ **Robust, lightweight housing**
  - Hard-coated aluminum alloy
- ⑥ **single-acting pneumatic cylinders**
  - only one pneumatic line required
  - Spring return
- ⑦ **Contact plate**
  - easy replaceable
  - embedded O-ring to increase the friction coefficient

## ► TECHNICAL DATA

Installation size	Adhesive force max.	Weight	IP class
	[N]	[kg]	
HM1030	27	0.06	IP30
HM1046	65	0.28	IP30
HM1078	220	1.2	IP30
HM1097	450	2.2	IP30

## ► FURTHER INFORMATION IS AVAILABLE ONLINE



All information just a click away at: [www.zimmer-group.com](http://www.zimmer-group.com). Find data, illustrations, 3D models and operating instructions for your installation size using the order number for your desired product. Quick, clear and always up-to-date.

# MAGNETIC GRIPPER

## INSTALLATION SIZE HM1030

### ▶ PRODUCT SPECIFICATIONS



### ▶ INCLUDED IN DELIVERY



1 [piece]  
Locking nut  
C043910002

### ▶ RECOMMENDED ACCESSORIES



#### ENERGY SUPPLY



**GVM5**  
Straight Fittings - Quick Connect Style

Order no.	Technical data
	<b>HM1030NC</b>
Adhesive force max. [N]	27
Operating pressure min. [bar]	3
Operating pressure max. [bar]	8
Operating temperature min. [°C]	5
Operating temperature max. [°C]	+80
Air volume per cycle [cm <sup>3</sup> ]	3.5
Weight [kg]	0.06

