

# 2-JAW RADIAL GRIPPER

## SERIES GG4000

### ▶ PRODUCT ADVANTAGES

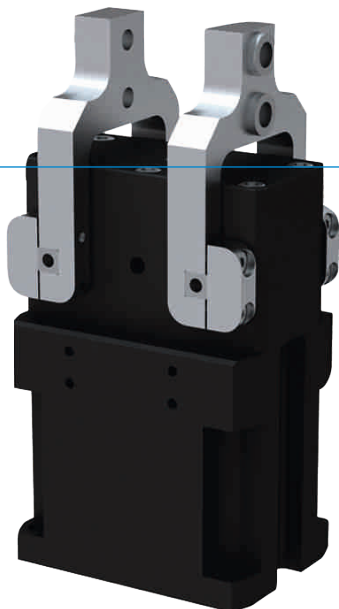

#### “The sealed”

##### ▶ Suitable for use under extreme conditions

The sealed rotation axis guarantees process reliability even under the harshest conditions







##### ▶ Smooth stroke configuration

You can adjust the 180° opening angle to be unique to your application using an adjusting screw

##### ▶ Failure-free continuous operation

Our uncompromising “Made in Germany” quality guarantees up to 10 million maintenance-free cycles

### ▶ SERIES CHARACTERISTICS

Installation size	Version	
GG40XX	NC	SC
 Spring closing C	•	•
 High-strength S		•
 10 million maintenance-free cycles (max.)	•	•
 Inductive sensor	•	•
 Magnetic field sensor	•	•
 Purged air	•	•
 IP 64	•	•



## ► BENEFITS IN DETAIL

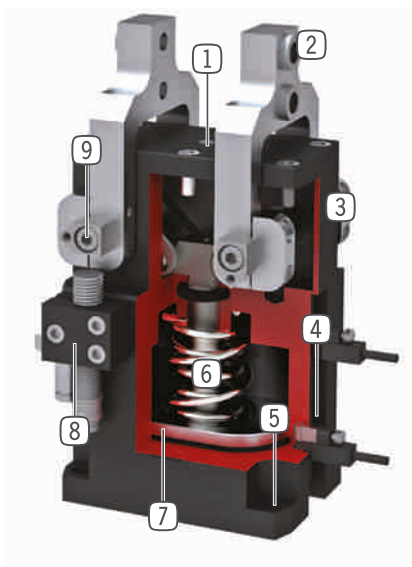

- ① **Stroke adjustment screw**
  - Infinitely adjustable opening stroke
- ② **Removable centering sleeves**
  - individual gripper finger mounting
- ③ **Robust, lightweight housing**
  - Hard-coated aluminum alloy
- ④ **Sensing slot**
  - mounting and positioning of magnetic field sensors
- ⑤ **Mounting and positioning**
  - mounting possible from several sides for versatile positioning
- ⑥ **Integrated gripping force safety device**
  - spring integrated into cylinder as energy storage
- ⑦ **Position sensing**
  - permanent magnet for direct monitoring of piston movement
- ⑧ **Mounting block**
  - mounting for inductive proximity switch
- ⑨ **Sealed rotation point**
  - for use under extreme conditions

## ► TECHNICAL DATA

Installation size	Stroke per jaw [°]	Gripping force [N]	Weight [kg]	IP class
GG4032	20 - 90	430 - 460	0,25	IP64
GG4040	20 - 90	700 - 800	0,5	IP64
GG4049	20 - 90	1000 - 1150	0,85	IP64
GG4058	20 - 90	1650 - 1900	1,4	IP64
GG4072	20 - 90	1950 - 2700	2,45	IP64
GG4084	20 - 90	3500 - 4000	4,5	IP64

## ► FURTHER INFORMATION IS AVAILABLE ONLINE



All information just a click away at: [www.zimmer-group.com](http://www.zimmer-group.com). Find data, illustrations, 3D models and operating instructions for your installation size using the order number for your desired product. Quick, clear and always up-to-date.

# 2-JAW RADIAL GRIPPER

## INSTALLATION SIZE GG4072

### ▶ PRODUCT SPECIFICATIONS



#### ▶ Gripping force diagram

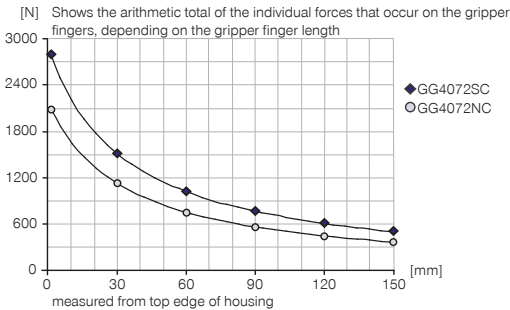

#### ▶ Forces and moments

Displays static forces and moments that can also have an effect, besides the gripping force.

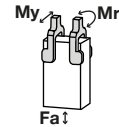

Mr [Nm]	41
My [Nm]	41
Fa [N]	1100

### ▶ INCLUDED IN DELIVERY



4 [piece]  
Centering Disc  
**DST42000**



1 [piece]  
Stroke adjustment screw  
**HES0018**



2 [piece]  
Flow Control Valves - with Swivel joint  
**DRV1-8X6**

### ▶ RECOMMENDED ACCESSORIES



#### ENERGY SUPPLY



**GV1-8X8**  
Straight Fittings - Quick Connect Style



**DSV1-8**  
Pressure safety valve



**DSV1-8E**  
Pressure safety valve with quick exhaust



#### SENSORS



**MFS02-S-KHC-P1-PNP**  
Magnetic field sensor straight, cable 0.3 m - M8 connector



**MFS01-S-KHC-P2-PNP**  
2-point sensor angled, cable 0.3 m - M8 connector



**MFS02-S-KHC-P2-PNP**  
2-point sensor straight, cable 0.3 m - M8 connector



#### SENSORS



**KB8-49**  
Mounting block



**NJ8-E2S**  
Inductive proximity switch - Connector M8



**MFS01-S-KHC-P1-PNP**  
Magnetic field sensor angled, cable 0.3 m - M8 connector



#### CONNECTIONS / OTHER



**KAG500**  
Plug-in connector Straight Cable 5m - Socket M8 (female)



**KAW500**  
Plug-in connector Angled Cable 5m - Socket M8 (female)



**S8-G-3**  
Plug-in connector customizable Straight - Connector M8

Order no.	► Technical data	
	GG4072NC	GG4072SC
Stroke per jaw [°]	90	20
Gripping moment in closing at 0° [Nm]	69	94
Gripping moment secured by spring min. [Nm]	10	21
Gripping force in closing [N]	1950	2700
Length of the gripper fingers max. [mm]	145	145
Permissible weight per jaw max [kg]	0.65	0.65
Closing time [s]	0.21	0.06
Opening time [s]	0.34	0.175
Repetition accuracy +/- [mm]	0.05	0.05
Operating pressure min. [bar]	4	4
Operating pressure max. [bar]	8	8
Nominal operating pressure [bar]	6	6
Operating temperature min. [°C]	5	5
Operating temperature max. [°C]	+80	+80
Air volume per cycle [cm <sup>3</sup> ]	130	100
Weight [kg]	2.45	2.45

