

# 3-JAW CONCENTRIC GRIPPERS WITH LONG STROKE SERIES GD500

## ▶ PRODUCT ADVANTAGES



### “The flat”

- ▶ **Reduced installation height due to horizontal drive**  
Reduces the interference contours for your application
- ▶ **Proven T slot guide**  
This established and proven guiding technology stands for the highest process reliability like no other
- ▶ **Failure-free continuous operation**  
Our uncompromising “Made in Germany” quality guarantees up to 10 million maintenance-free cycles

## ▶ SERIES CHARACTERISTICS

### Installation size

#### GD5XX

 10 Mio	10 million maintenance-free cycles (max.)	●
 +	Inductive sensor	●
 IP 40	IP40	●



## ► BENEFITS IN DETAIL

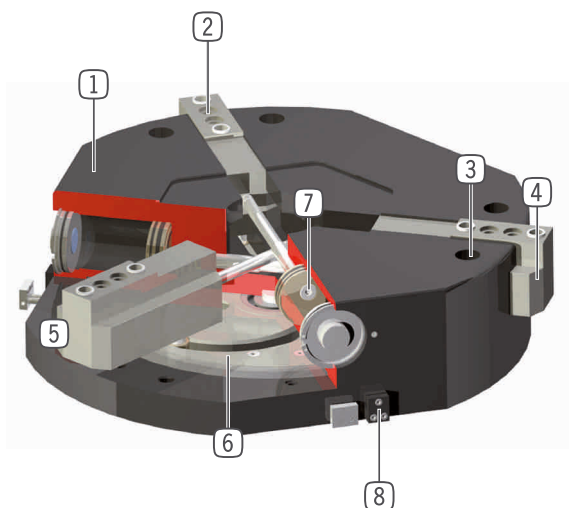

- ① **Robust, lightweight housing**
  - Hard-coated aluminum alloy
- ② **Removable centering sleeves**
  - quick and economical positioning of the gripper fingers
- ③ **Mounting and positioning**
- ④ **Gripper jaw**
  - ground, hardened steel
  - individual gripper finger mounting
- ⑤ **Precise T-Slot guide**
  - high forces and moments capacity
- ⑥ **Cam**
  - synchronized jaw movement
- ⑦ **Drive**
  - three double-acting pneumatic cylinders
- ⑧ **Mounting block**
  - mounting for inductive proximity switch

## ► TECHNICAL DATA

Installation size	Stroke per jaw [mm]	Gripping force [N]	Weight [kg]	IP class
GD530	30	1300	7.4	IP40
GD540	40	2480	22.3	IP40
GD560	60	2480	34.3	IP40

## ► FURTHER INFORMATION IS AVAILABLE ONLINE



All information just a click away at: [www.zimmer-group.com](http://www.zimmer-group.com). Find data, illustrations, 3D models and operating instructions for your installation size using the order number for your desired product. Quick, clear and always up-to-date.

# 3-JAW CONCENTRIC GRIPPERS WITH LONG STROKE INSTALLATION SIZE GD530

## ▶ PRODUCT SPECIFICATIONS



### ▶ Gripping force diagram

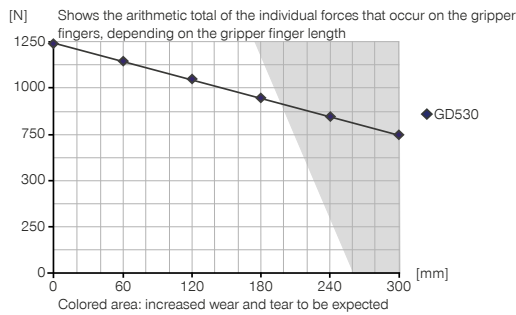

### ▶ Forces and moments

Displays static forces and moments that can also have an effect, besides the gripping force.

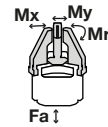

Mr [Nm]	300
Mx [Nm]	200
My [Nm]	300
Fa [N]	8000

## ▶ INCLUDED IN DELIVERY



2 [piece]  
Mounting block  
**KB8K**



6 [piece]  
Centering Disc  
**DST41600**

## ▶ RECOMMENDED ACCESSORIES



### ENERGY SUPPLY



**GV1-4X8**  
Straight Fittings - Quick Connect Style



**WV1-4X8**  
Angled Fittings - Quick Connect Style



**DEV08**  
Quick Exhaust Valve



**DSV1-8**  
Pressure safety valve



**DSV1-8E**  
Pressure safety valve with quick exhaust



### SENSORS



**NJ8-E2**  
Inductive proximity switch - Cable 5 m



### SENSORS



**NJ8-E2S**  
Inductive proximity switch - Connector M8



### CONNECTIONS / OTHER



**KAG500**  
Plug-in connector Straight Cable 5m - Socket M8 (female)



**KAW500**  
Plug-in connector Angled Cable 5m - Socket M8 (female)



**S8-G-3**  
Plug-in connector customizable Straight - Connector M8



**S12-G-3**  
Plug-in connector customizable Straight - Connector M12

Order no.	GD530
Stroke per jaw [mm]	30
Gripping force in closing [N]	1300
Gripping force in opening [N]	1300
Closing time [s]	0.3
Opening time [s]	0.3
Repetition accuracy +/- [mm]	0.05
Operating pressure min. [bar]	3
Operating pressure max. [bar]	8
Nominal operating pressure [bar]	6
Operating temperature min. [°C]	5
Operating temperature max. [°C]	+80
Air volume per cycle [cm <sup>3</sup> ]	170
Weight [kg]	7.4

► Technical data

