

# AXIS COMPENSATION MODULES

## SERIES ARP

### ▶ PRODUCT ADVANTAGES



#### ▶ Lockable centre placement

When moving your robot, you can fix the equalizer in place so that uncontrolled movements of the workpiece do not take place

#### ▶ Extremely flat design

This structure reduces the moment load for your robot to a minimum and makes it possible to use smaller and more affordable sizes

#### ▶ Variable balancing force and moment

Adjust the equaliser to your handling weight by mounting a spring package based on desired rigidity

### ▶ THE BEST PRODUCT FOR YOUR APPLICATION



#### ▶ Our products welcome the challenge!

Extreme conditions, all over the world—our tried and tested components and systems give you endless possibilities.

Find the best product for your specific use:

[www.zimmer-group.com](http://www.zimmer-group.com)

## ► BENEFITS IN DETAIL

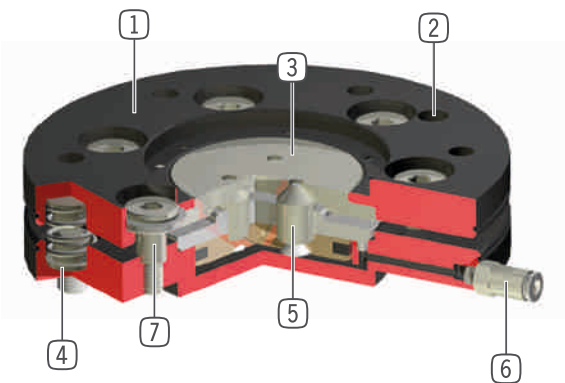

- ① **Robust, lightweight housing**
  - Hard-coated aluminum alloy
- ② **Robot connecting flange**
  - partial mounting circle in accordance with EN ISO 9409-1
- ③ **Locking**
  - 3 locking pistons
  - nitrated steel
- ④ **Spring package**
  - version size 63, stronger one is available
  - version size 100, 3 springs can be removed
- ⑤ **Locking drive**
  - single-acting pneumatic cylinder
- ⑥ **Energy supply**
- ⑦ **Guiding bolts with ball cup**

## ► FURTHER INFORMATION IS AVAILABLE ONLINE



### ► **Technical Information**

All information just a click away at: [www.zimmer-group.com](http://www.zimmer-group.com)

Find data, illustrations, 3D models and operating instructions for your installation size using the order number for your desired product.

Quick, clear and always up-to-date.



# AXIS COMPENSATION MODULES

## INSTALLATION SIZE AR100P

### PRODUCT SPECIFICATIONS



#### Spring Pack 1 (pre-assembled)

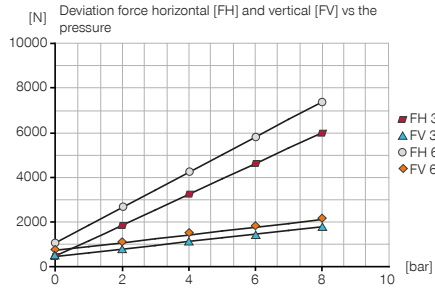

#### Forces and moments

Shows static forces and moments which may impact on the axis compensation module.

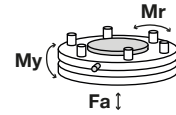

Mr [Nm]	500
My [Nm]	500
Fa [N]	2100

#### Spring Pack 1 (pre-assembled)

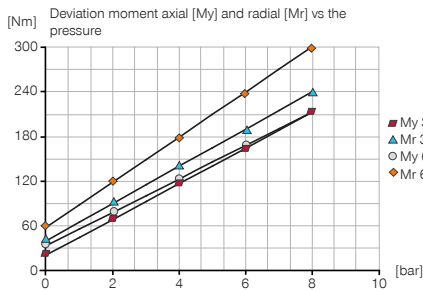

#### Spring Pack 2

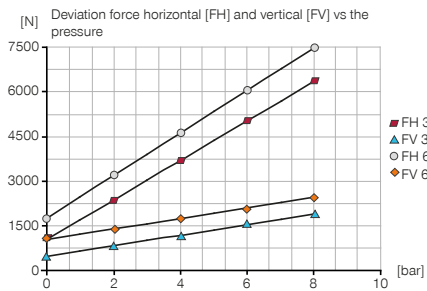

#### Spring Pack 2

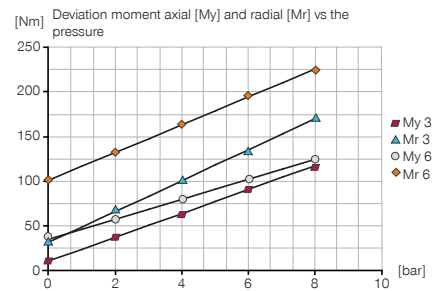

### INCLUDED IN DELIVERY



Cylinder Screw

C7984080169



Spring Pack 1 (pre-assembled)

CFED10050



Spring Pack 2

CFED10060

### RECOMMENDED ACCESSORIES



Straight Fittings - Quick Connect Style

GVM5



Angled Fittings - Quick Connect Style

WVM5

Order no.	Technical Data*
Connecting flange according EN ISO 9409-1	TK 100
Installation Height [mm]	26
Recommended handling weight [kg]	30
Horizontal deviation +/- [mm]	2
Horizontal deviation +/- [°]	1
Vertical deviation [mm]	2
Vertical deviation [°]	1
Centering force when locking [N]	1400
Repetition accuracy Horizontal +/- [mm/°]	0.05
Repetition accuracy Vertical +/- [mm/°]	0.05
Air volume per cycle [cm³]	8.5
Operating pressure min. [bar]	1
Operating pressure max. [bar]	8
Operating temperature min. [°C]	5
Operating temperature max. [°C]	+80
Moment of inertia [kg/cm²]	17
Weight [kg]	0.85

\*All data measured at 6 bar

